

HP® CP1215 • 1518 CARTRIDGE REMANUFACTURING INSTRUCTIONS



HP® CP1215 COLOR LASER PRINTER



HP® CP1215 TONER CARTRIDGE



REMANUFACTURING THE HP CP1215 BLACK & COLOR TONER CARTRIDGES

By Mike Josiah

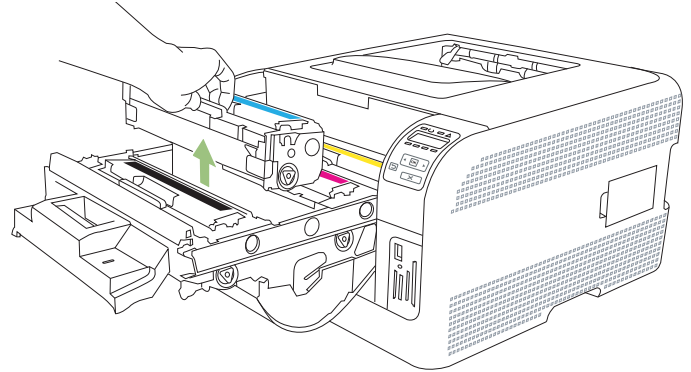
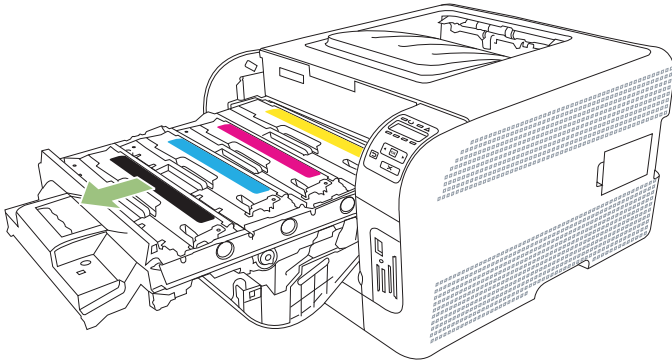

First released in April 2008, the CP1215 series of color laser printers are based on a 12ppm black, 8ppm color, 600 DPI engine (2400 DPI with RET in the CP1215 and up to 3600 DPI with RET in the CP1518ni/CM 1312nfi MFP). The 1215 cartridges are an all in one type cartridge that consists of the toner supply, drum, and waste chamber. Like the CLJ-2600 these machines use an in-line, or single pass system. The difference here is that all four cartridges are stacked in line front to back instead of on top of each other as in the 2600.



Because of this new machine layout, we will take a moment and run through the printer theory before we get started. The cartridge itself looks different from any previous Canon/HP cartridges I have seen. It's basically a rectangular shaped cartridge that comes with a toner seal and a snap-on drum cover across the bottom to protect the drum. New machines ship with starter cartridges rated for 750 pages so users will run out of toner fairly quickly.

These cartridges can be disassembled fairly easily. Unlike the CLJ 2600, no cutting of the drum or cutting of any kind is necessary. There is a small problem removing the feed roller and thus filling the cartridge, but nothing too problematic. That will be explained later in the instructions. In going through the service manual, I found an intriguing setting. Under the OPTIMIZE menu, you can turn on a setting that reduces backgrounding. There are also extra cleaning and voltage settings under that menu, but I found the on/off setting for backgrounding to be interesting. The default setting for the Optimize feature is OFF.

The chips in these cartridges are the same as most other HP color cartridges, the chip does not need to be changed in order for the cartridge to work. The toner low circuitry will be disabled, but after the user presses the "SELECT" button, the cartridge will work. The display will then alternate from "READY" to "Unauthorized Supply in Use."

THE PRINTERS BASED ON THE CP1215 ENGINE ARE:

- HP Color LaserJet CP1215
- HP Color LaserJet CP1515n
- HP Color LaserJet CP1518ni
- HP Color LaserJet CM1312nfi MFP

THE CARTRIDGES USED IN THESE MACHINES ARE:

- CB540A (Black) 2,200 pages \$98.58 USD List***
- CB541A (Cyan) 1,400 pages \$91.16 USD List***
- CB543A (Magenta) 1,400 pages \$91.16 USD List***
- CB542A (Yellow) 1,400 pages \$91.16 USD List***

*Pricing current as of May 2008.

With the new machines shipping with 750 page black and color starter cartridges, there is sure to be a fast growing demand for remanufactured cartridges.

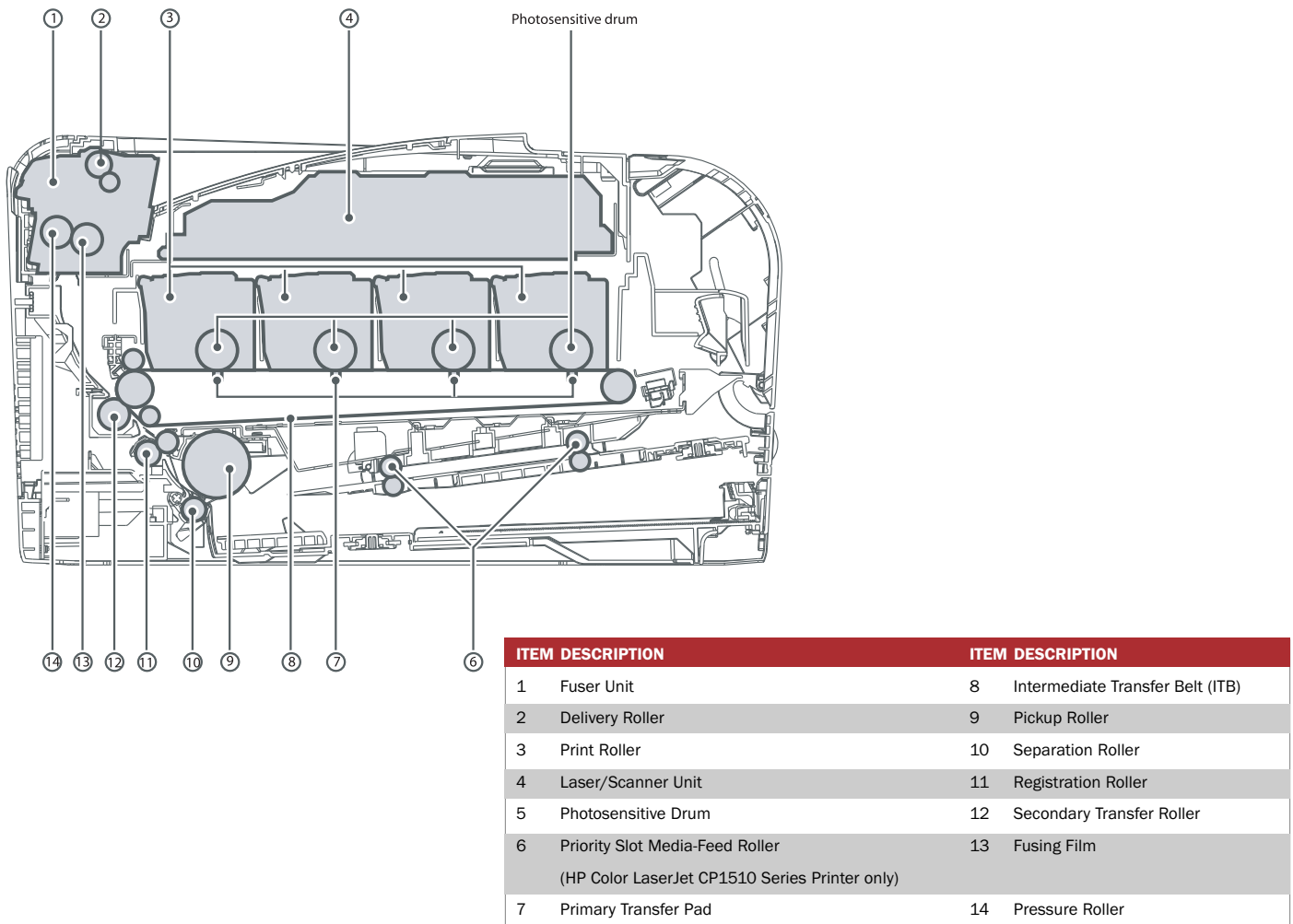

The color toner cartridge printing process happens in a series of stages or steps. For the purpose of this article, we will call them stages. The figure above shows the basic layout of the cartridges and how they relate to one-another and the printer. Note that while this is still a single pass system, the layout is completely different from any previous Canon/HP machines.

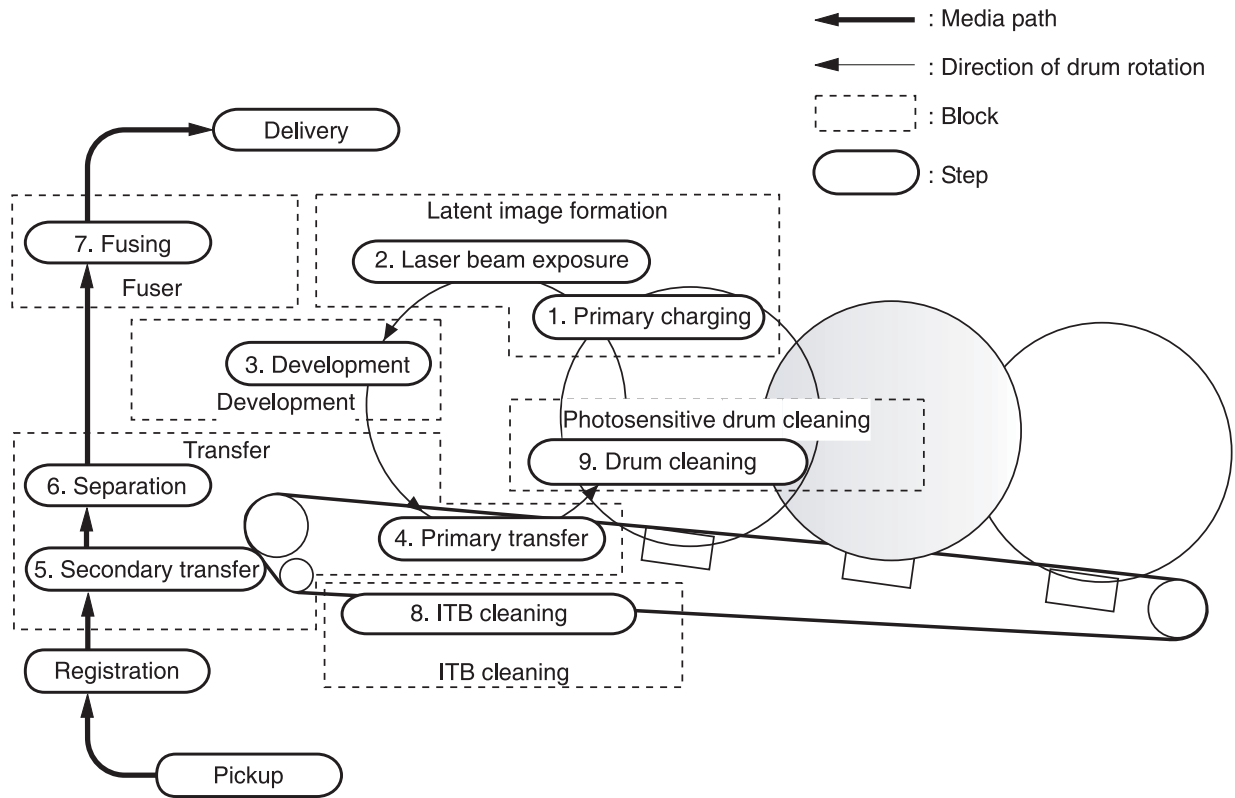
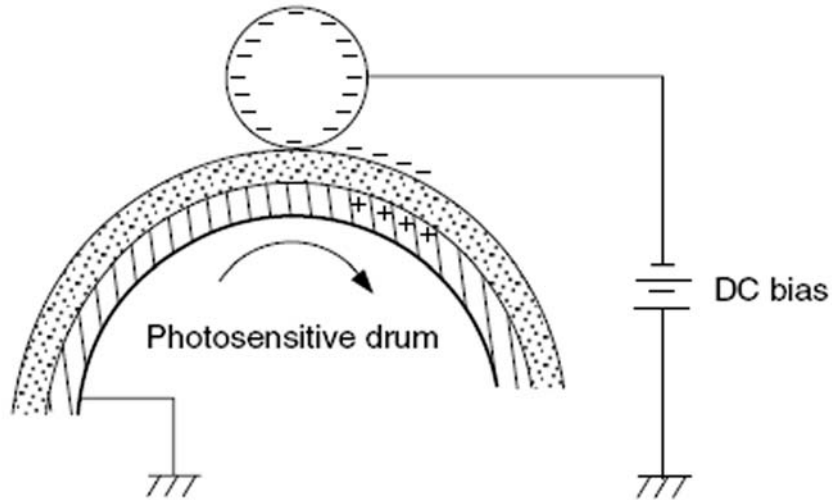
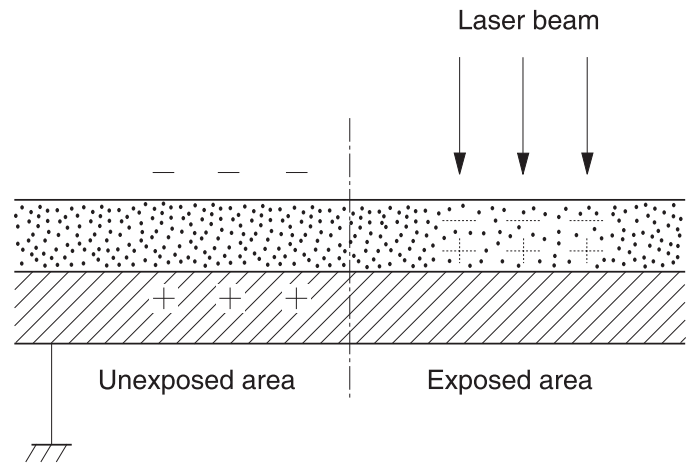
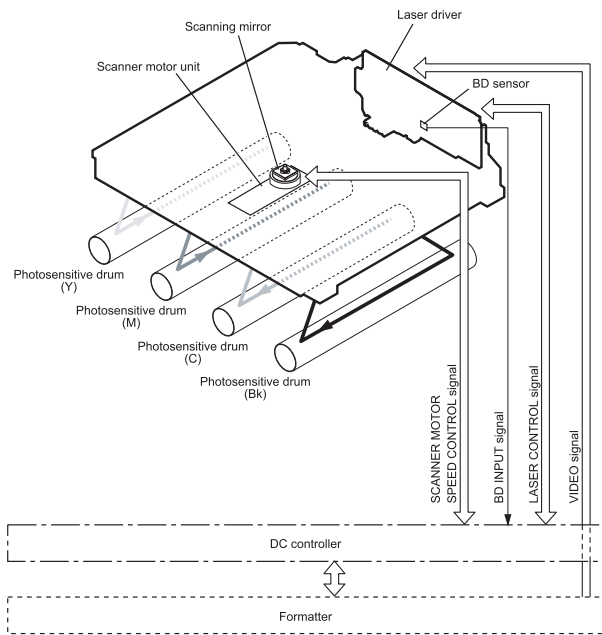

Illustration shows the complete image formation process.



In the **first stage**, the Primary Charge Roller (PCR) places a uniform negative DC voltage on the OPC drum surface.

The amount of the negative DC voltage placed on the drum is controlled by the printer's intensity setting.



In the **second stage**, the laser beam is fired onto a rotating mirror (called the scanner). As the mirror rotates, the beam is reflected into a set of focusing lenses. The beam then strikes the drums surface, reducing the negative charge and leaving a latent electrostatic image on the drum. The areas where the laser did not strike the drum will retain the higher negative charge. Technology has advanced tremendously in these machines as there is one laser/scanner unit for all four colors. I imagine there are still 4 separate lasers, but I'm not sure about the scanner motor(s). The only way to know for sure is to open one up, and I have not done that (yet).

The **third or developing stage** is where the toner is developed on the drum by the developing section (or supply chamber), which contains the toner particles. The development stage is actually made up of two steps: toner charging, and the actual development. In the toner charging stage, the toner stirring blade turns inside the hopper. As it turns, friction causes a negative potential to develop on the toner. In addition, a foam feed roller brings the toner to the developer roller and also places a negative charge on the toner. These two charges help ensure a uniform charge on the toner. Once the toner is properly charged, the toner will coat the developer roller. The toner is also held onto and attracted to the developer roller by another negative DC bias voltage. This voltage is controlled by the printer's intensity setting and causes either more or less toner to be attracted by the developer roller. This in turn will either increase or decrease the print density. The amount of toner on the developer roller is controlled by the doctor blade, which uses pressure to keep the amount of toner on the roller constant.

As the laser exposed areas of the OPC Drum approach the developer roller, the toner particles are attracted to the drum's surface due to the opposite voltage potentials of the toner, and laser exposed areas of the OPC drum.

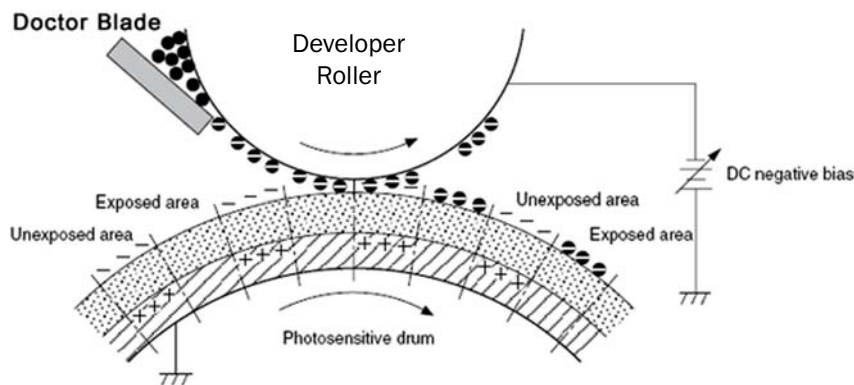

The **fourth stage** is the **transfer stage**. This is where there are some large differences from monochrome printers and also from other color lasers. In the Primary transfer stage the transfer pad (Not a roller in this case) which is located directly opposite each OPC drum, places a positive DC bias charge on the back of the ITB or Image Transfer Belt. Each toner cartridge has a separate transfer charge pad. The image is transferred from the drum directly to the ITB. This process is repeated for each color cartridge in the following order: Yellow, Magenta, Cyan, and Black. At the same time, the paper is moving between the Secondary transfer roller and the ITB. As the ITB passes the paper, the positive charge is picked up, and draws the negatively charged toner off the Belt and onto the paper.

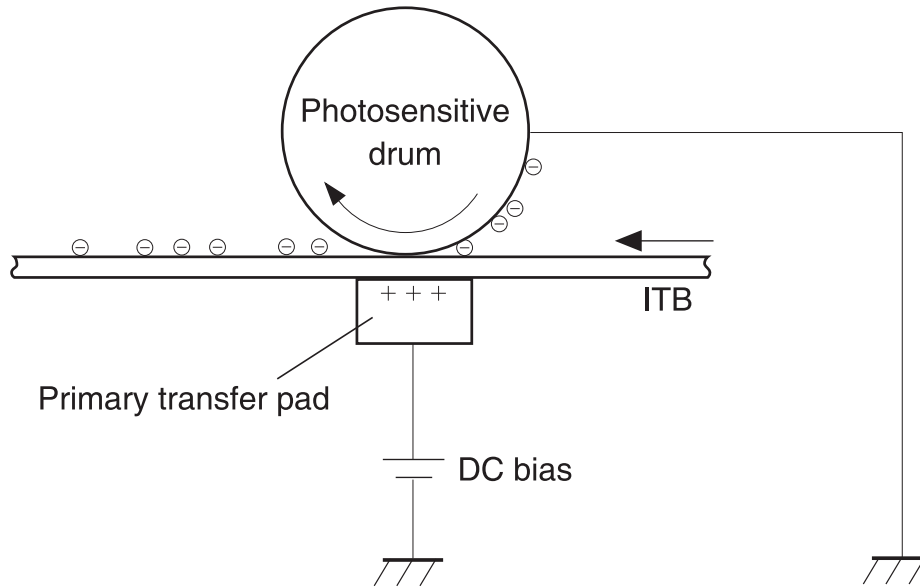

The paper separates from the ITB belt as the belt reaches the top of its path and turns back down to start the process again. The static charge on the back of the paper is decreased with static charge eliminator. This helps stabilize the paper feed, and also prevents toner flares (spots) under low temperature and low humidity conditions.

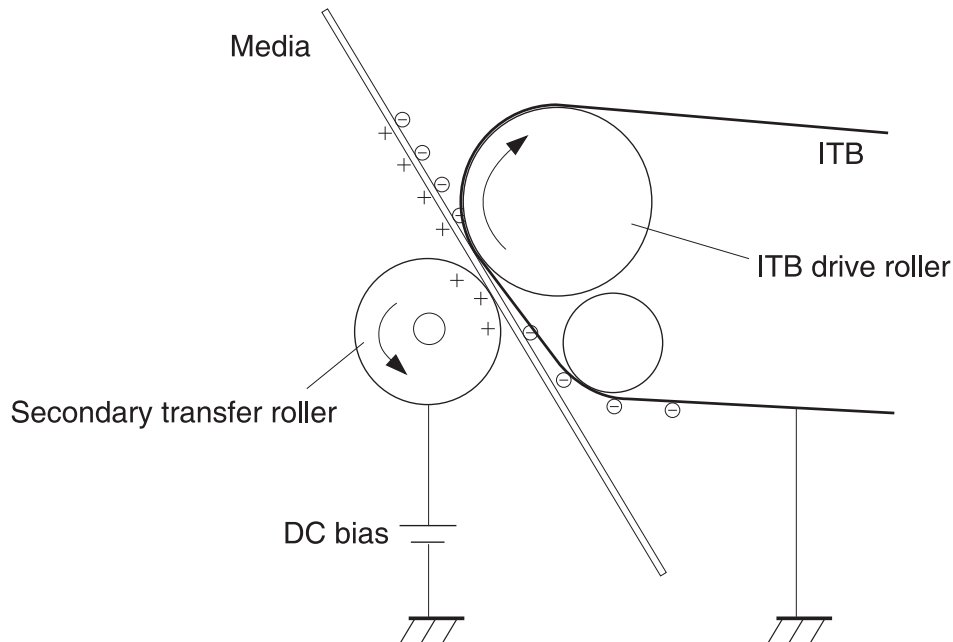

In the **fifth stage**, the image is then fused onto the paper by the fuser assembly. The fuser Assembly is comprised of the upper heating assembly and lower pressure roller. The lower pressure roller presses the page up into the upper heating assembly which then melts the toner into the paper. This heating assembly consists of a flexible sleeve with a ceramic heating coil inside. This type of fuser affords “instant on” fusing with little to no wait time, and low power consumption.

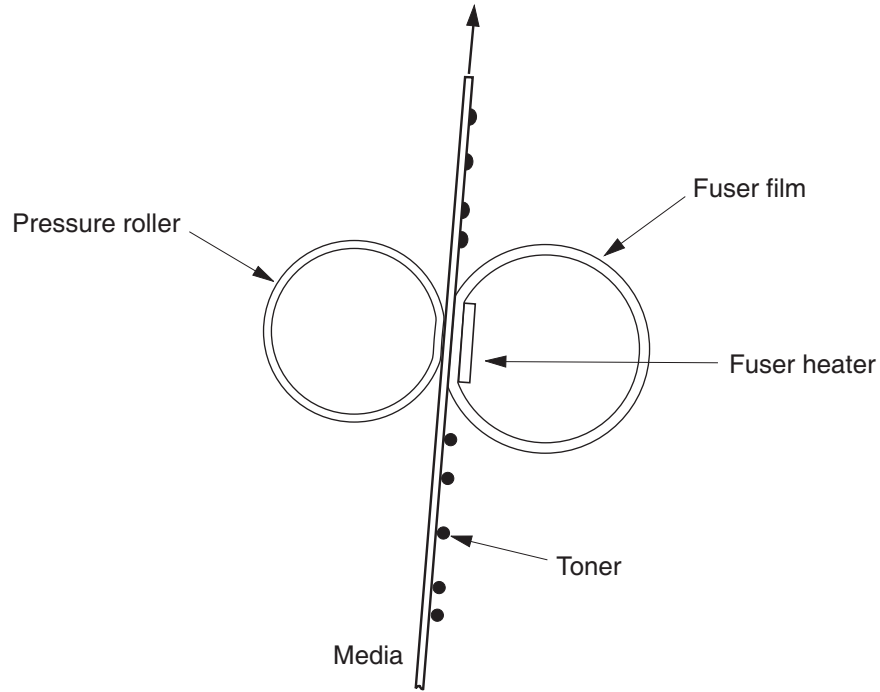

ITB CLEANING

The ITB is cleaned by both the ITB cleaning Roller, and the ITB Cleaning brush. Both the roller and brush have a DC positive bias placed on them which in turn places a positive DC Bias on the residual toner. The Residual toner is then picked up by the OPC drum (Because of the positive bias) and then cleaned off the drum by the wiper blade.

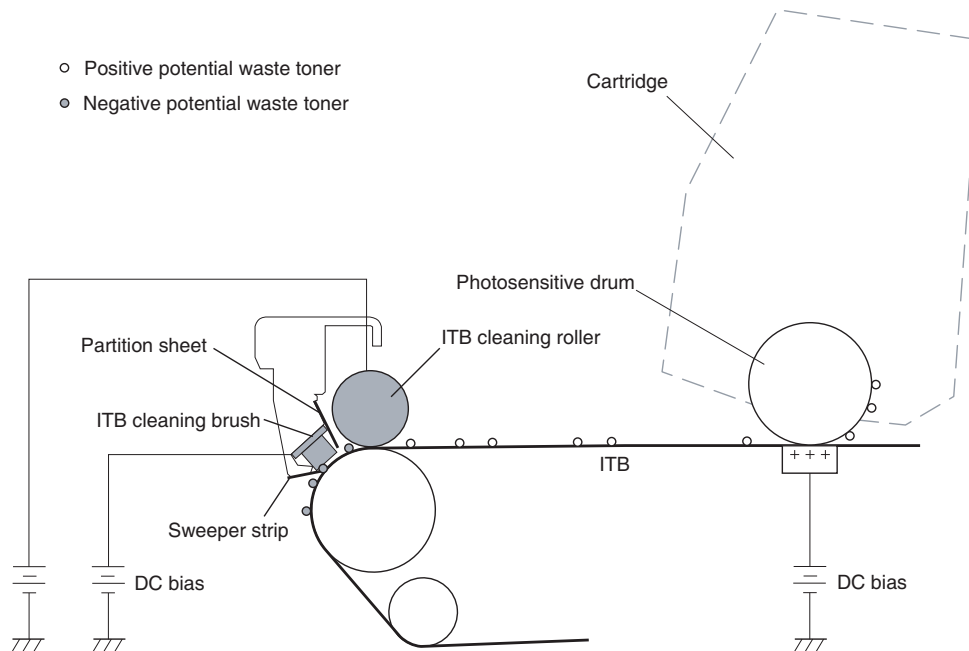

OPC DRUM CLEANING

The drum is cleaned after the image is transferred to the paper by the wiper blade. This part is fairly standard; the wiper blade scrapes the toner off the drum, and the recovery blade guides it into the waste chamber.

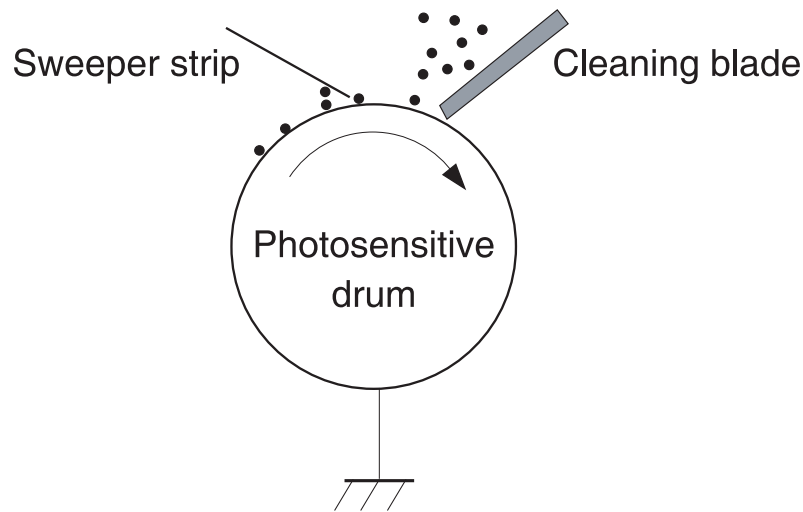
**PRINTER CALIBRATION**

At the start of all this is the cartridge detection process, toner level detection, and then the calibration cycle. The printer will calibrate itself whenever the printer is turned on (Within 15 minutes), when a new toner cartridge is installed and after 48 hours of run time. Calibration consists of a solid block and halftone of each color being printed to the ITB. As the printed areas get to the top of the belt, a sensor will detect them, measure the density, and adjust the printer accordingly. All of the calibration time settings are user controllable.

Taking test prints, cartridge troubleshooting as well as minor printer troubleshooting will be covered at the end of this article.

REQUIRED TOOLS

1. Toner approved vacuum
2. A small screwdriver (common style)
3. A Phillips head screwdriver
4. Needle nose pliers

SUPPLIES REQUIRED

1. CP1215 dedicated color toner
2. New replacement chip
3. New long life CP1215 drum
4. New wiper blade
5. New toner feed roller (optional)
6. New PCR (optional)
7. New doctor blade (optional)
8. Drum cover
9. Lint-free cloths
10. Conductive grease

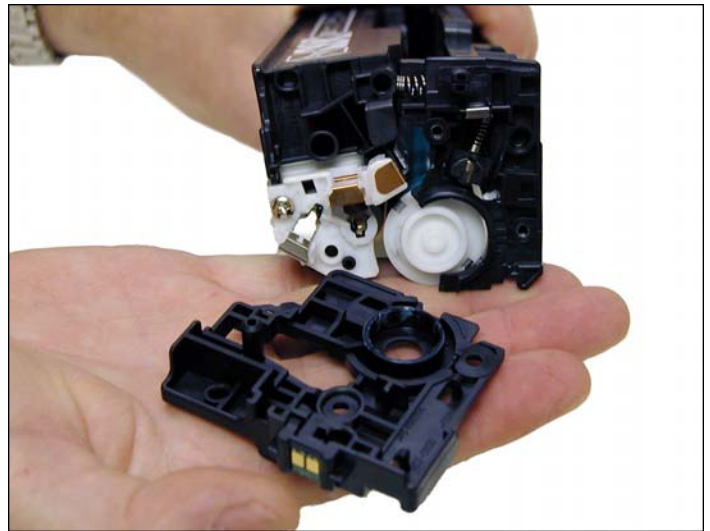
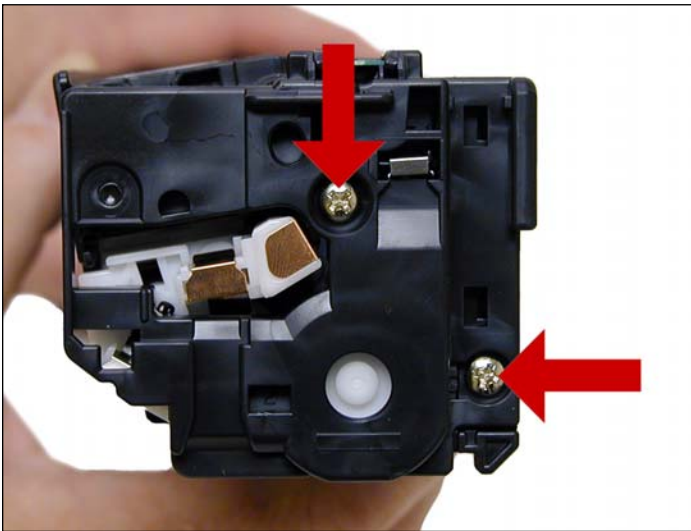

1. With the label on top and facing you, remove the two screws from the left side end cap. Remove the end cap.

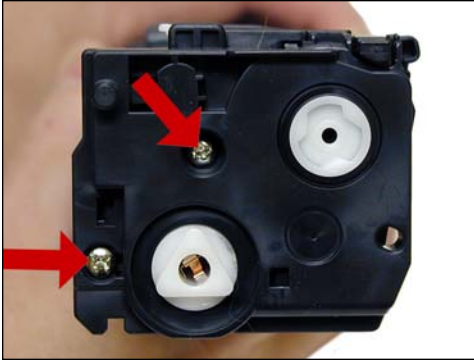

2. On the right side, remove the two screws and end cap.

Be careful! The two halves will start to separate, and the drum will come loose.



3. Flip the waste chamber upside down, and remove the drum.



4. Remove the PCR. Clean with your preferred PCR cleaner and place aside.



5. Remove the two screws and wiper blade.



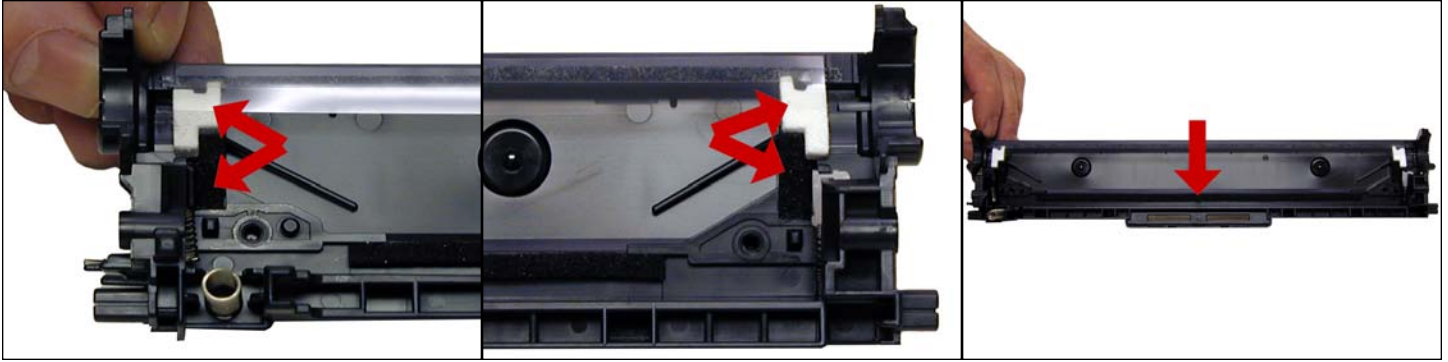

6. Clean out all the waste toner from the chamber. Make sure all the wiper blade seals are clean.



7. Coat the new wiper blade with your preferred lubricant and install. Install the two screws.

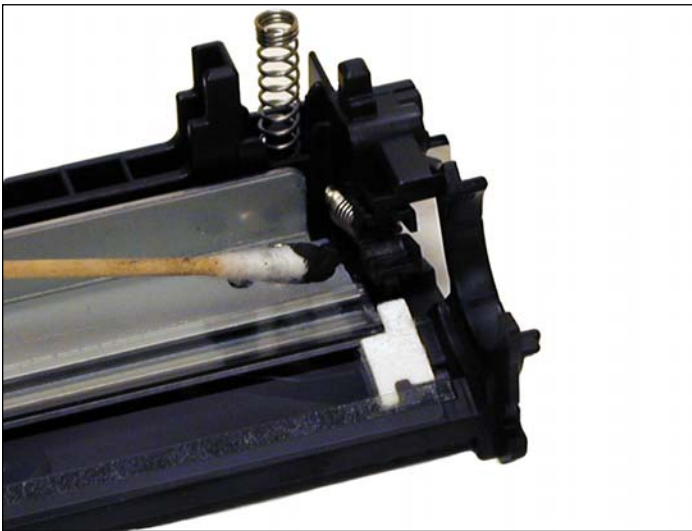

8. Install the cleaned PCR. Make sure to place a small amount of conductive grease on the black PCR holder.

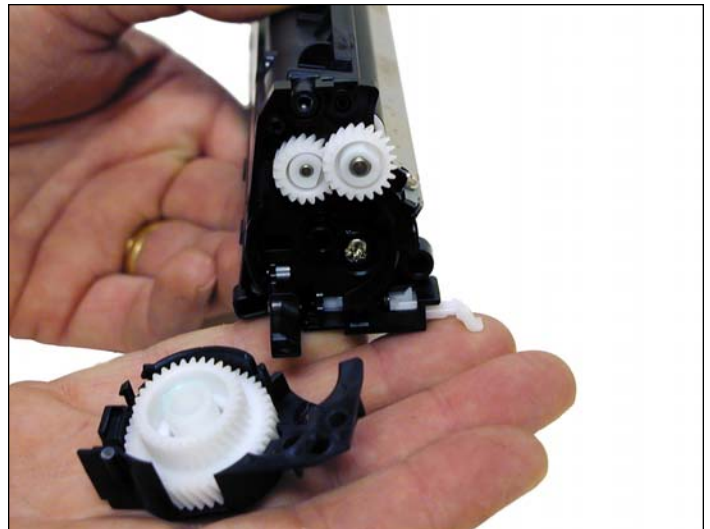
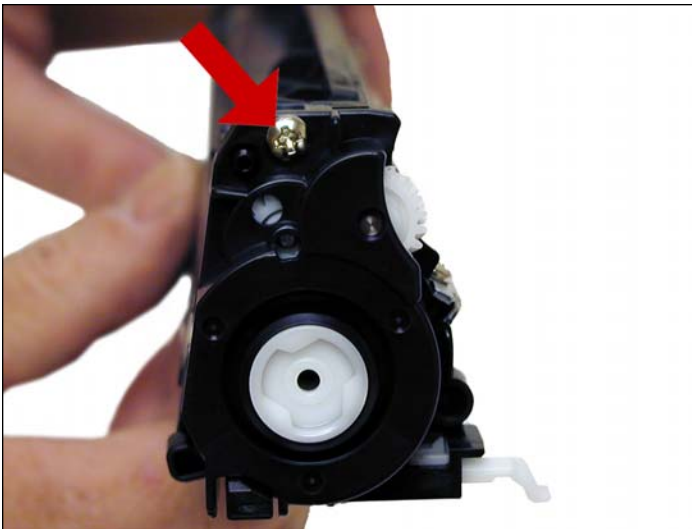

9. On the supply chamber, remove the screw from the gear/non-contact side end cap.

Carefully and gently work the end cap off the hopper. There is a small plastic pin that will break off.

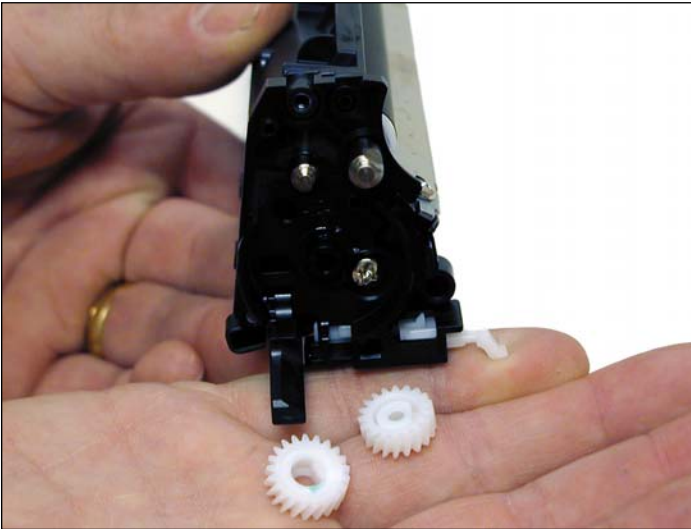

10. Remove the two gears.

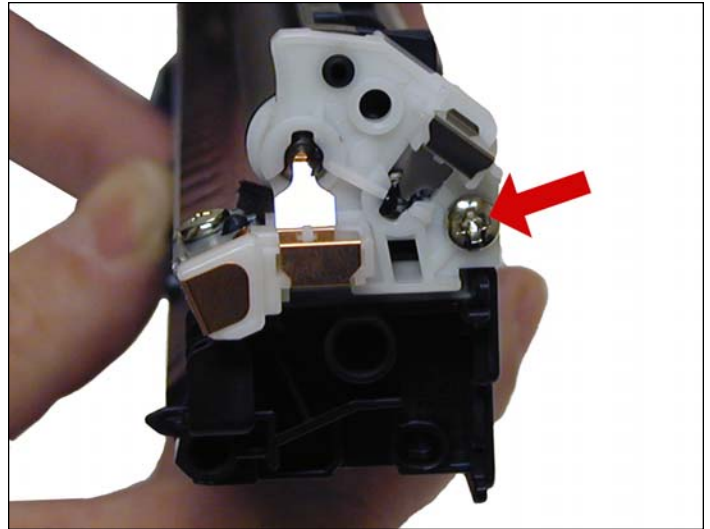

11. Remove the screw on the contact side end cap.



12. Slide the developer roller over and remove.



13. Remove the two screws and doctor blade.

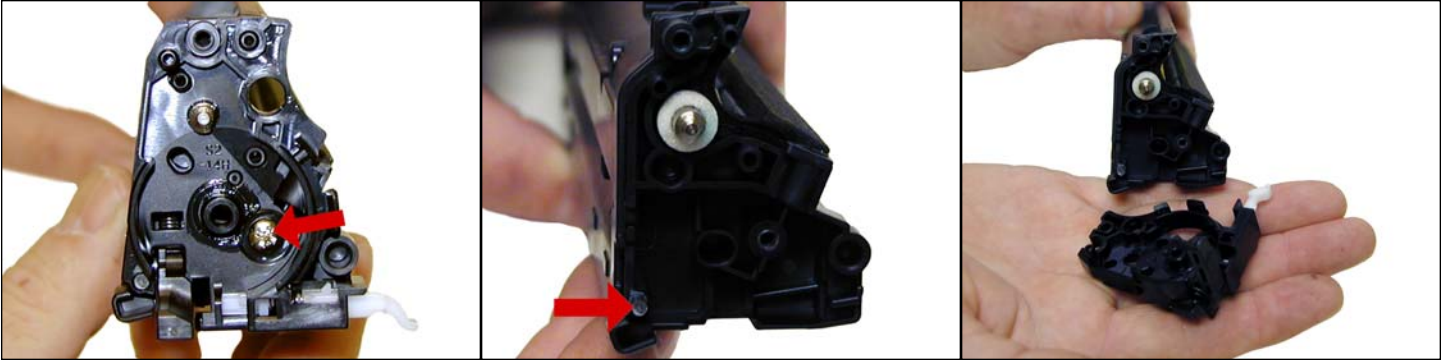

14. On the gear side of the hopper, remove the screw and inner end cap. Carefully work this end cap free. Use a small screwdriver if necessary to free the end cap from the plastic pin that broke earlier. Note the spring loaded arm assembly. I believe this arm is part of the cartridge detection system but nothing is mentioned about it in the service manual. The sensors for this are hidden by the transfer belt in the machine. We will figure out their purpose but for now, it's just a guess.



15. At this point, while tight, you can clean and fill the hopper with 1215 toner.

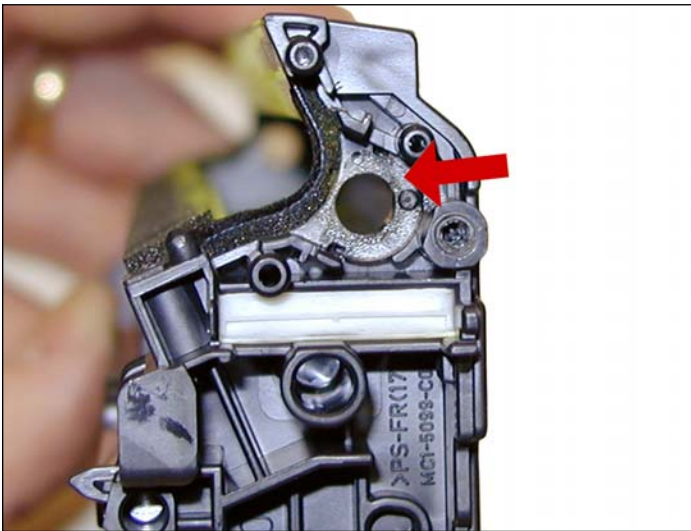

NOTE: HP/Canon created a bit of a block for us here. The clear bushing located on the right side of the hopper (pictured) is glued in. The opposite side bushing is integral to the hopper. If you wish to install a seal, change the feed roller, or just have better access to the hopper, the feed roller must be pulled over to one side compressing the foam.

First remove the two white felt seals.



At this point we do not know if this will damage the roller or affect the printing at all.

So far in our tests it has not, but it's too early to say for sure.



16. If you have not already done so, fill the hopper with HP CLJ CP1215 toner and install the feed roller.



17. Install the two white felt seals on the feed roller shaft.

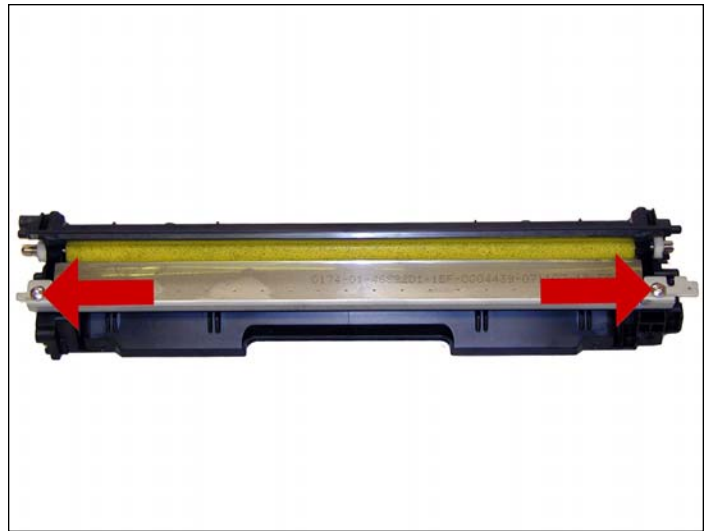

18. Clean the doctor blade foam seal. Install the doctor blade and two screws.



19. Install the developer roller.

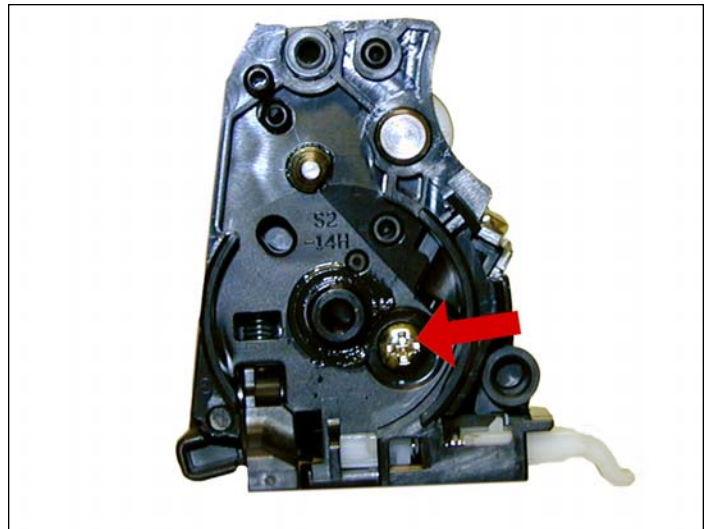

20. Install the inner end cap and screw. This end cap has a tight fit and snaps in place. Be careful here, the screw hole strips out easily.

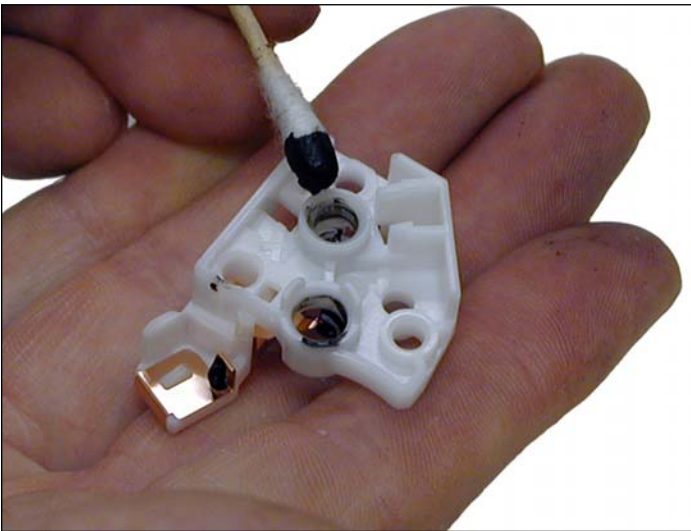

21. Clean the contact on the contact end cap with a cotton swab and alcohol. Replace the conductive grease with fresh grease. Remember, more is not better with this grease.

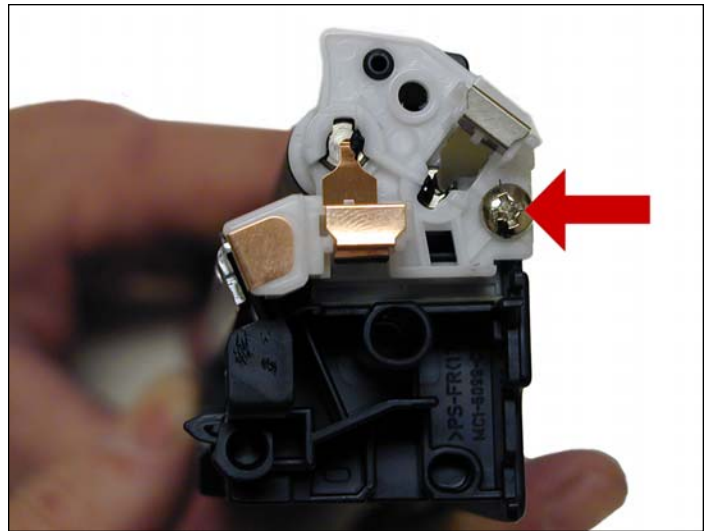

22. Replace the contact end cap and screw.



23. Replace the two gears on the feed and developer roller shafts.

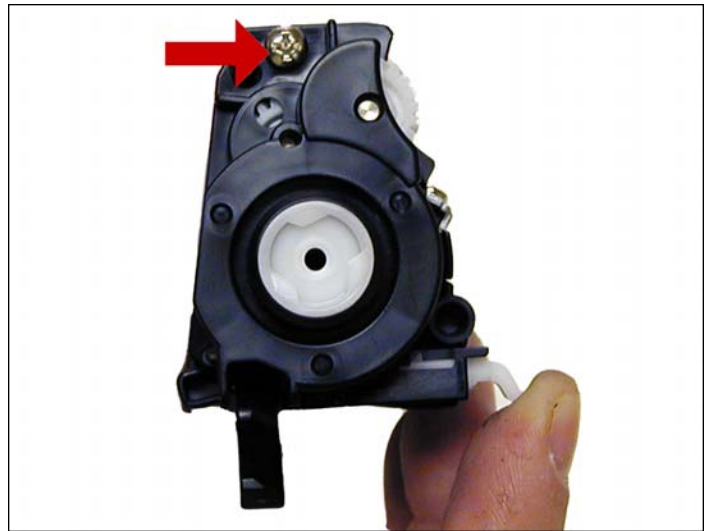
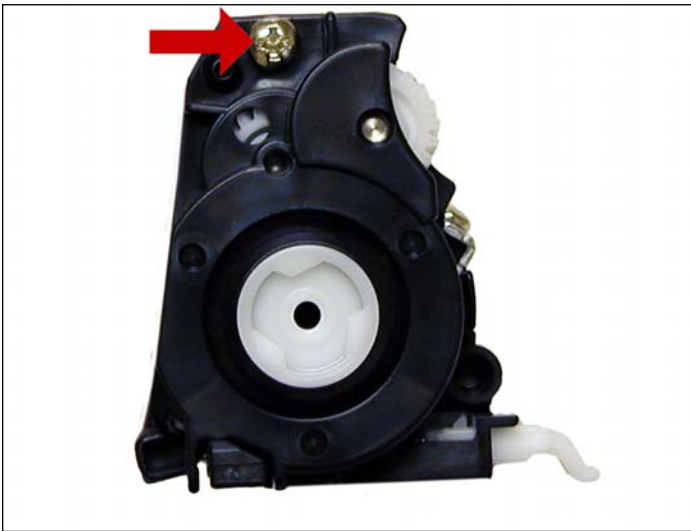

24. Install the gear end cap and screw. Make sure the spring arm works!.

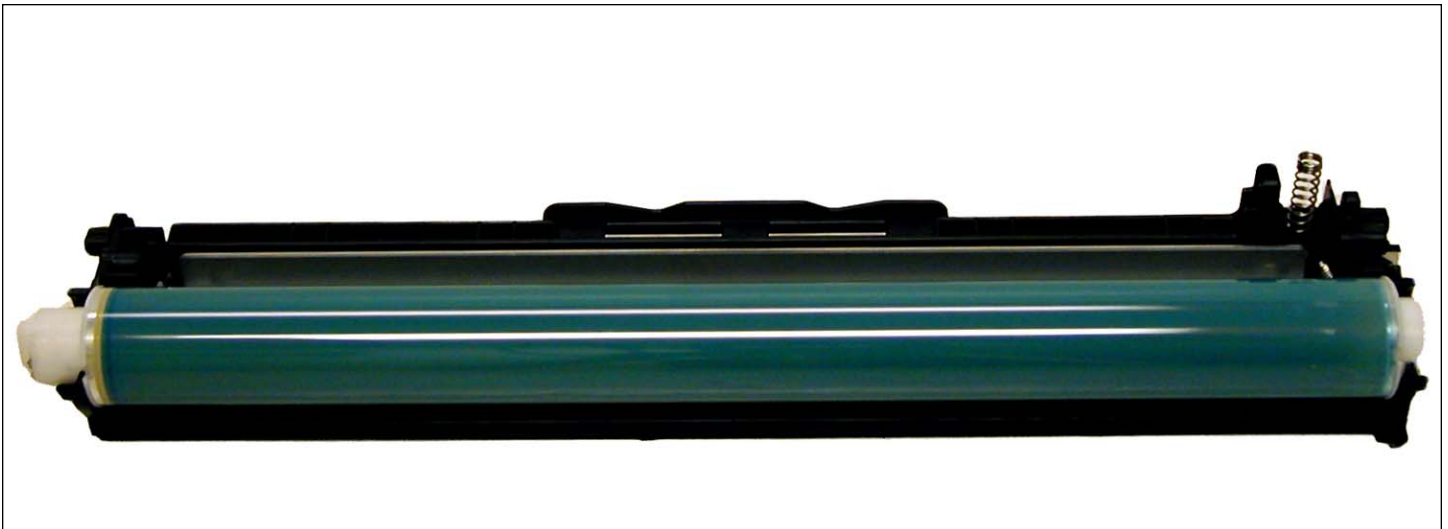

25. Coat the drum with you preferred lubricant and install the drum in the waste hopper.

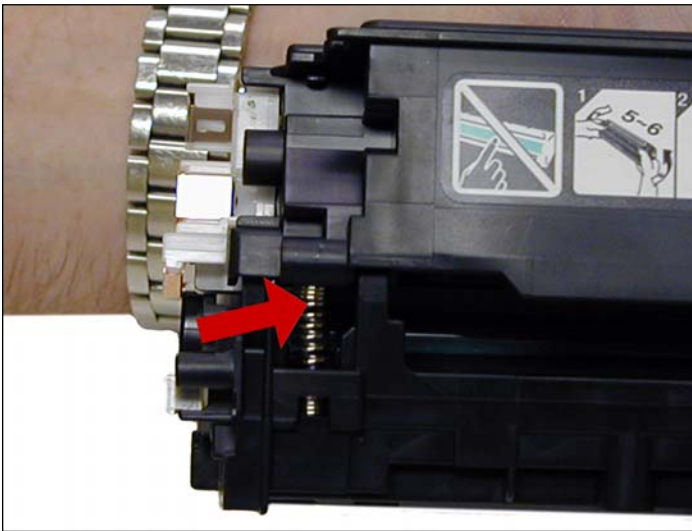

26. Hold the two halves together. Align the spring on one side and the spring loaded arm on the other.

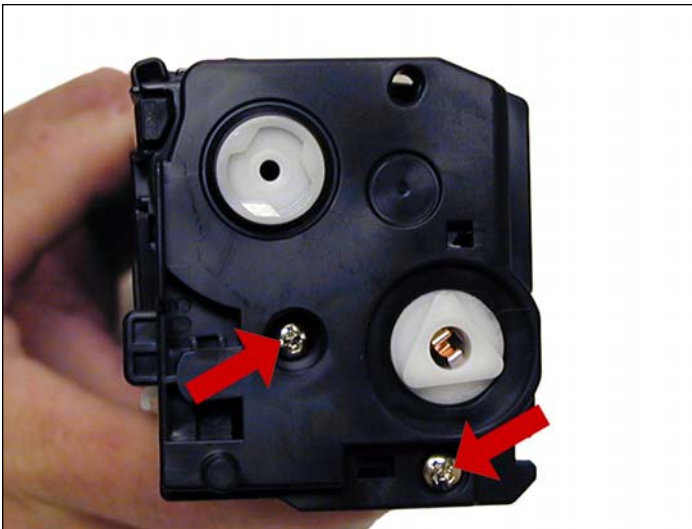

27. Install the outer gear side and cap and two screws.



28. Install the remaining outer end cap on the contact side of the cartridge and two screws.

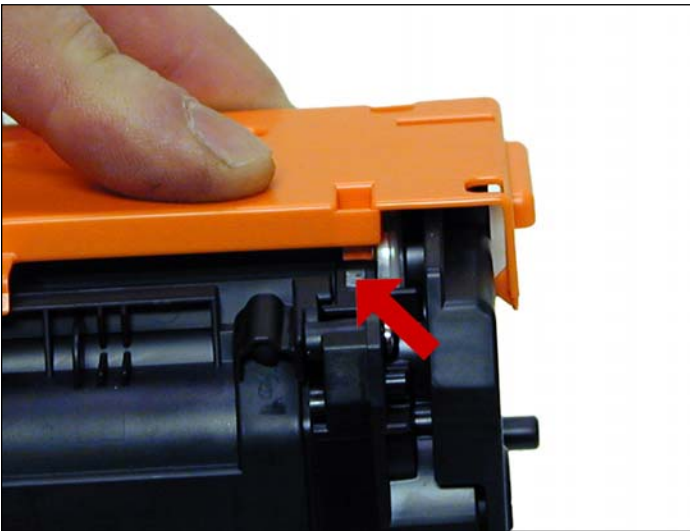

29. Install the drum cover on to the cartridge. Spread the two halves apart slightly so it fits properly.

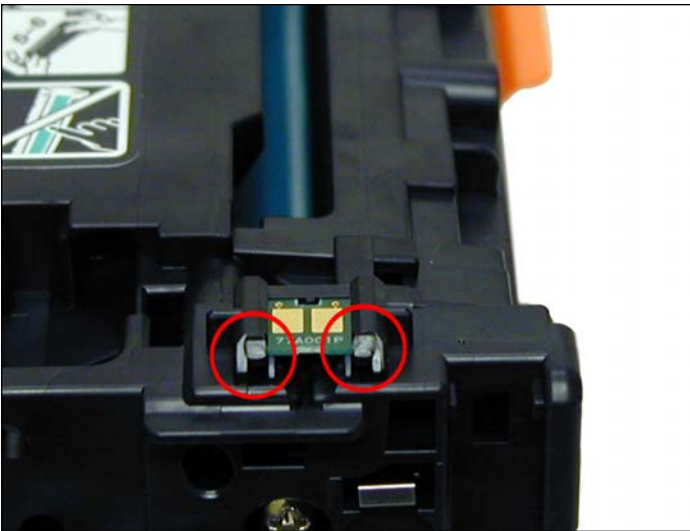

30. Remove the chip by cutting the plastic off the edges of both sides of the chip.

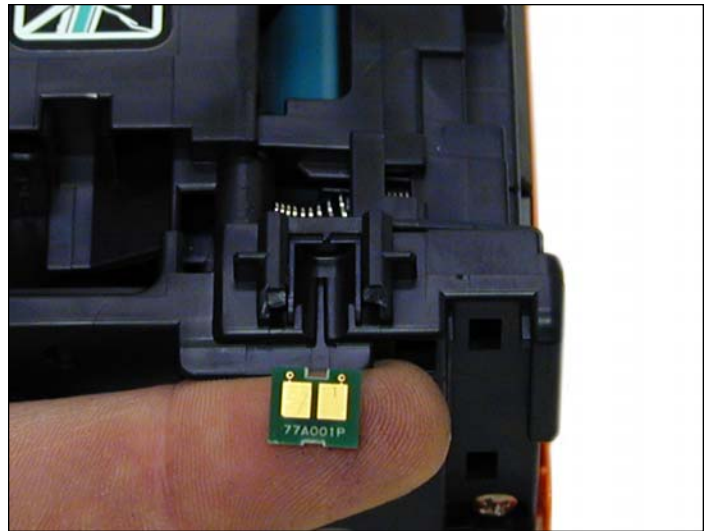

31. Remove and replace the chip. If the new replacement chip is loose in the slot, close off the top edges with small amounts of hot glue.

TAKING TEST PRINTS**Demo Page CP1210:**

The demo page for this machine can only be run from the toolbox provided with the software driver.

Demo Page CP1518:

1. Press OK to open the menus.
2. Press the left or right arrow until "REPORTS" appears on the display. Press OK.
3. Press the left or right arrow until "DEMO PAGE" appears on the display. Press OK.
4. Press X to exit the menus.

Configuration Page CP1210:

1. Press and hold the RESUME button for 3 seconds.
2. Both the configuration page and a supplies status page will print out.

Configuration Page CP1518:

1. Press OK to open the menus.
2. Press the left or right arrow until "REPORTS" appears on the display. Press OK.
3. Press the left or right arrow until "CONFIG REPORT" appears on the display. Press OK.
4. Press X to exit the menus.

Engine Test Page:

1. With the printer turned off, open the front and rear doors.
2. Turn the power on, and close both doors within 10 seconds.
3. An Engine test page will print that contains multiple horizontal colored lines.

REPETITIVE DEFECT CHART

ITB	633.6mm (Distance is longer than one full page)
OPC Drum	75.8mm
Transfer Rollers	57.0mm
Fuser Pressure Roller	56.8mm
Fuser Sleeve	56.5mm
Registration Roller	44.0mm
RS Roller(Feed roller)	28.5mm
Primary Charge Roller	26.7mm
Developer Roller Sleeve	22.3mm

SOME OF THE MORE COMMON PRINTER ERROR MESSAGES

CP1210: These machines have simple lights that show if a specific cartridge is low or out of toner, paper jam etc. More detailed messages are displayed on the PC it is attached to.

CP1518: Most of the error messages are in plain English, but some are numeric only. We have listed the more common ones here. Most of the internal errors listed in the service manual just state something like "Internal hardware error." They are not very helpful.

10.000X	Supply Error: Chip cannot be read or cartridge is not properly installed.
10.0000	Black Chip error
10.0001	Cyan Chip error
10.0002	Magenta Chip error
10.0003	Yellow Chip error
10.100x	Supply Error: Cartridge/Chip is missing
10.1000	Black cartridge/chip missing
10.1001	Cyan cartridge/chip missing
10.1002	Magenta cartridge/chip missing
10.1003	Yellow cartridge/chip missing
51.XX	Printer Error: Internal hardware error (that's all the service manual states!)

CALIBRATE NOW

Sometimes the only way to fix print quality issues is to force a calibration:

1. Open the HP Color LaserJet TOOLBOX.
2. Click the DEVICE SETTINGS folder, then click on the PRINT QUALITY page.
3. In the area for color calibration, select CALIBRATE NOW.
4. Click APPLY to start the process.

CARTRIDGE LIFE SETTINGS

Lastly there are some interesting settings the user can set for cartridge life. On the CP1518 machines open up the System Setup menu/Print Quality/Cartridge Low or Replace Supplies menu through the control panel. For the CP1215 machine these functions are only available through the Tool Box. For Toner Low, you can set the percentage that the printer starts reporting low toner. This can be set from 1-20%. The default setting is 10%.

Replace Supplies: This Setting can be turned on or off. If the Override out setting is chosen, you can continue printing until the toner is depleted. The other setting is Stop at Out. This setting stops all printing until the cartridge is replaced. This is the default setting.

PRINT DENSITY SETTINGS

On the CP1518 machines open up the System Setup menu/Print Quality/Print Density menu through the control panel. For the CP1215 machine these functions are only available through the Tool Box. There are actually multiple sub settings that can be set under density. As you can see, these settings can get a little intense and complicated.

Contrasts: Contrast is the range of difference between light (Highlight) and dark (Shadow) colors. To increase the overall range between light and dark colors, increase the Contrasts setting.

Highlights: Highlights are colors that are nearly white. To darken highlight colors, increase the Highlights setting. This adjustment does not affect midtone or shadow colors.

Midtones: Midtones are colors that are halfway between a white and solid density. To darken midtone colors, increase the midtone setting. This adjustment does not affect highlight or shadow colors.

Shadows: Shadows are colors that are nearly a solid density. To darken shadow colors, increase the shadows setting. This adjustment does not affect highlight or midtone colors.